

BDMFuse: Multi-scale network fusion for infrared and visible images based on base and detail features

SI Hai-Ping¹, ZHAO Wen-Rui¹, LI Ting-Ting¹, LI Fei-Tao¹, FERNANDO Bacao²,
SUN Chang-Xia¹, LI Yan-Ling^{1*}

- (1. College of Information and Management Science, Henan Agricultural University, Zhengzhou 450046, China;
2. NOVA Information Management School, Universidade Nova de Lisboa, Lisboa1070-312, Portugal)

Abstract: The fusion of infrared and visible images should emphasize the salient targets in the infrared image while preserving the textural details of the visible images. To meet these requirements, an autoencoder-based method for infrared and visible image fusion is proposed. The encoder designed according to the optimization objective consists of a base encoder and a detail encoder, which is used to extract low-frequency and high-frequency information from the image. This extraction may lead to some information not being captured, so a compensation encoder is proposed to supplement the missing information. Multi-scale decomposition is also employed to extract image features more comprehensively. The decoder combines low-frequency, high-frequency and supplementary information to obtain multi-scale features. Subsequently, the attention strategy and fusion module are introduced to perform multi-scale fusion for image reconstruction. Experimental results on three datasets show that the fused images generated by this network effectively retain salient targets while being more consistent with human visual perception.

Key words: infrared image, visible image, image fusion, encoder-decoder, multi-scale features

BDMFuse: 基于红外与可见光图像基础特征和细节特征的多尺度融合

司海平¹, 赵文沛¹, 李婷婷¹, 李飞涛¹, FERNANDO Bacao², 孙昌霞¹, 李艳玲^{1*}
(1. 河南农业大学 信息与管理科学学院, 河南 郑州 450046;
2. Universidade Nova de Lisboa, NOVA Information Management School, Lisboa1070-312, Portugal)

摘要: 红外与可见光图像的融合结果应该突出红外图像的显著目标, 保留可见光图像的纹理细节。为满足上述要求, 提出一种基于自编码器的红外与可见光图像融合方法。编码器根据优化目标构建基础编码器和细节编码器, 用于提取图像的低频信息与高频信息。这种提取方式可能会导致部分信息未被捕捉, 因此提出补偿编码器来补充信息。同时, 采取多尺度分解来更全面地提取图像特征。解码器将低频、高频和补充信息相加获取多尺度特征。随后, 引入注意力策略与 Fusion 模块进行多尺度融合, 实现图像重建。在三个数据集上的实验结果表明, 该网络生成的融合图像能有效保留突出目标, 同时更符合人类的视觉感知。

关键词: 红外图像; 可见光图像; 图像融合; 编码器-解码器; 多尺度特征

中图分类号: TP391.4

文献标识码: A

Introduction

Infrared and visible image fusion is a vital task in

image processing^[1]. Infrared images, captured through thermal radiation, are less affected by external factors but often suffer from a significant loss of texture details

Received date: 2024-07-25, **revised date:** 2024-09-11

收稿日期: 2024-07-25, **修回日期:** 2024-09-11

Foundation items: Supported by the Henan Province Key Research and Development Project (231111211300), the Central Government of Henan Province Guides Local Science and Technology Development Funds (Z20231811005), Henan Province Key Research and Development Project (231111110100), Henan Provincial Outstanding Foreign Scientist Studio (GZS2024006), and Henan Provincial Joint Fund for Scientific and Technological Research and Development Plan (Application and Overcoming Technical Barriers) (242103810028)

Biography: SI Hai-Ping (1978-), male, Shangqiu, professor. Research interests are image processing. E-mail: haiping@henau.edu.cn

* **Corresponding author:** E-mail: lyl_lingling@163.com

and structural information^[2]. In contrast, visible images contain rich texture information but are more sensitive to environmental changes^[3]. Therefore, combining infrared and visible images in a bimodal manner can generate high-quality images^[4].

To maximize the retention of useful information in fused images, various methods have been developed. Traditional image fusion techniques operate in either the spatial domain or the transform domain. Spatial domain methods directly process image pixels, whereas transform domain methods handle the frequency representation of images using transformations such as the Fourier transform or wavelet transform^[5,6]. While these traditional methods have produced satisfactory fusion results, they largely depend on heuristic fusion rules. Consequently, traditional image fusion techniques often fall short of meeting the increasingly stringent fusion requirements.

In recent years, the feature extraction capabilities of deep learning have attracted significant attention from researchers. Studies have demonstrated that deep learning methods can substantially enhance the quality of fused image^[7]. Currently, deep learning-based image fusion methods can be broadly categorized into three types: autoencoder (AE)-based methods, convolutional neural network (CNN)-based methods, and generative adversarial network (GAN)-based methods. AE-based methods focus on encoding data to create a low-dimensional representation, which is then decoded to reconstruct the original data^[8]. CNN-based methods extract image features through local connections and shared weights^[9]. GAN-based methods employ adversarial training between a generator and a discriminator to produce high-quality images^[10].

Although methods for infrared and visible image fusion are relatively mature, there are still unresolved issues. Increasing the number of network layers enhances the network's expressive ability, but it also exacerbates the loss of image detail. This, to some extent, limits the further improvement of fusion image quality. Our proposed network effectively addresses this problem, with its main contributions being as follows:

(1) The encoder network constructs base and detail encoders to extract low and high frequency information based on the optimisation objective, and constructs compensation encoders to supplement the information.

(2) The decoder network first fuses the different scales of low-frequency, high-frequency, and compensatory information to obtain multi-scale features. These multi-scale features are then multiplied by the acquired attention map, and the Fusion module is introduced to perform multi-scale fusion for image reconstruction.

(3) Our proposed fusion method demonstrates superior fusion results in terms of both visual assessment and objective evaluation compared to nine other fusion algorithms on three public datasets.

1 Related works

1.1 Methods based on autoencoder

An autoencoder is an unsupervised learning model

commonly used for tasks such as data compression and feature extraction. The encoder maps input data into a low-dimensional feature space, while the decoder reconstructs the original data from this reduced space. Through this process, the autoencoder retains essential information and effectively captures significant feature representation^[11]. As a result, autoencoder have been widely applied in areas such as target detection^[12], target segmentation^[13], and early warning systems^[14].

In image processing, the feature extraction capabilities of self-encoders are extensively utilized in image fusion tasks. Image fusion aims to combine information from multiple image sources to generate richer and more informative results. Autoencoder is usually divided into three parts in this field: the encoder, the decoder, and the fusion layer. The encoder automatically learns the feature information of the source images without the need for manually designed features. The decoder maps the low-dimensional features extracted by the encoder back to the original space, adaptively reconstructing the image. Typically, image fusion methods based on autoencoders train the encoder and decoder during the training phase. In the testing phase, a fusion layer, such as an addition or maximum strategy, is introduced to merge the image features of infrared and visible.

Li et al.^[15] proposed a deep learning architecture that integrates convolutional layers, fusion layers, and dense blocks, where the output of each layer is connected to the outputs of other layers. Recognizing that the features extracted by a single branch might lack comprehensiveness, Li et al.^[16] introduced a method incorporating a multi-level residual encoder module and a decoder module with hybrid transmission. This design features a multi-level residual encoder module with two independent branches for extracting image features. Zhao et al.^[17] proposed a dual-branch structure for multimodal feature decomposition and image fusion. Tang et al.^[18] proposed a darkness-free infrared and visible image fusion method, which fully considers the intrinsic relationship between low-light image enhancement and image fusion, achieving effective coupling and information complementarity. Additionally, Tang et al.^[19] were the first to consider the gap between high-level vision tasks and image fusion, proposing a semantic-aware image fusion framework.

1.2 Multi-scale transform

Multi-scale transform is a technique for processing and analyzing information by decomposing an image or signal into different scales or frequency components^[20]. It can effectively capture local details and global features in images and is widely used in tasks such as image fusion, texture analysis and feature extraction. The commonly used multi-scale transforms mainly contain methods such as pyramid transformations^[21], wavelet transformations^[22], and non-subsampled multi-scale multi-directional geometric transformations^[23].

With the advancement of deep learning, researchers and scholars have integrated multi-scale transforms into deep learning-based networks. Lin et al.^[24] proposed

cross-scale fusion module for interactive fusion of features between encoder and decoder. Jian *et al.* [25] introduced a multi-scale encoder to extract featured image features and constructed a symmetric encoder-decoder with residual blocks (SEDRFuse) network for fusing infrared and visible images in night vision applications. Wang *et al.* [26] introduced a novel and efficient fusion network based on dense Res2net and dual nonlocal attention models. They integrated Res2net and dense connectivity into an encoder network, enabling the utilization of multiple available receptive fields to extract multi-scale features. This approach aims to retain as much effective information as possible for the fusion task.

2 Proposed fusion method

This section provides a detailed description of the proposed architecture for infrared and visible image fusion, encompassing the encoder, decoder, and training specifics.

2.1 Network architecture

Our proposed infrared and visible image fusion method (BDMFuse) adopts an end-to-end network architecture. The encoder employs three branches: the base encoder, detail encoder, and compensation encoder. The base encoder extracts low-frequency information from the image, the detail encoder captures high-frequency information, and the compensation encoder gathers information not captured by the other encoders. Each encoder operates at three different scales, and their outputs are fed into the decoder. Multi-scale features are first generated by summing the low-frequency, high-frequency, and compensatory information from different scales. These multi-scale features are then fused to achieve image reconstruction. The specific overall architecture of the training and testing phases is shown in Fig. 1.

2.2 Encoder

Inspired by the literature [27], we construct the base encoder, detail encoder, and compensation encoder with

the idea of solving for the optimal solution. The base encoder extracts low-frequency features by minimizing Eq. (1) to obtain the optimal solution.

$$B_n = B_1 - \gamma_{B1} \times B_m, \quad (1)$$

where B_1 is the image acquired after applying a blur filter to the input image and γ_{B1} is the tuning hyperparameter. B_n ($n \in \{1, 2, 3\}$) is the decomposed base image. B_m ($m \in \{1, 2, 3\}$) is the low-frequency features of different scales obtained after convolution operations of different depths, which are represented as shown below:

$$B_m = L_n - \gamma_{B2} \times E_n, \quad (2)$$

where L_n ($n \in \{1, 2, 3\}$) denotes features of different scales obtained after convolution operations of different depths, E_n ($n \in \{1, 2, 3\}$) denotes high-frequency features of different scales extracted from the E_n feature map, and γ_{B2} is the tuning hyperparameter.

The detail encoder minimizes Eq. (3) to obtain the optimal solution.

$$D_n = D_1 - \gamma_{D1} * D_m, \quad (3)$$

where D_1 is the image obtained after applying Laplace filter to the input image and D_m ($m \in \{1, 2, 3\}$) denotes the high frequency features at different scales obtained from the convolution operation that has been performed at different depths. γ_{D1} is the tuning hyperparameter. D_n ($n \in \{1, 2, 3\}$) is the decomposed detail image.

The compensation encoder also adopts the method of finding the optimal value to obtain the feature information, which is similar to the detail encoder and will not be repeated. We obtain the compensation filter by Eq. (4)

$$C_1 = 1 - B_1 - D_1. \quad (4)$$

The base encoder network is depicted in Fig. 2. We adopt two processing methods to extract the low-frequency information of the input image. One is to take low pass filter and the other is to take convolution operation. First, feature coarse extraction is performed, followed by the addition of the CBAM attention mechanism [28] to emphasize effective information. To capture more compre-

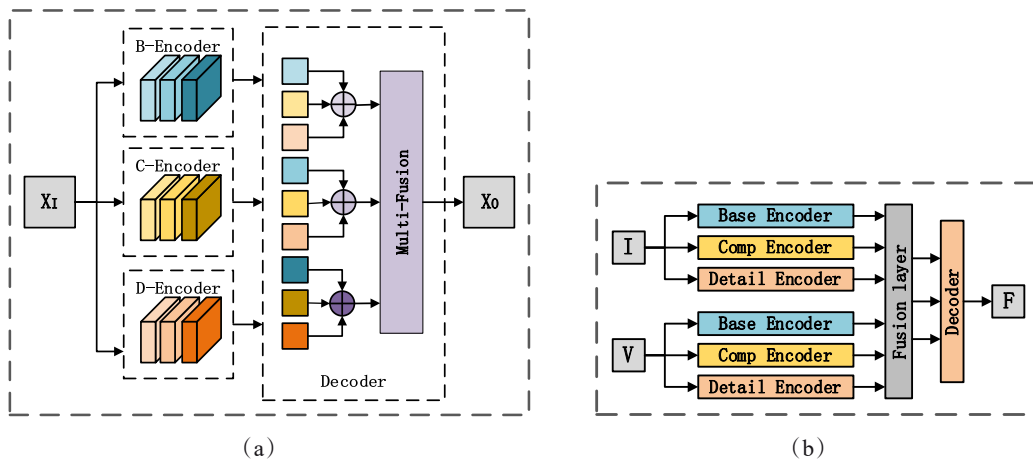

Fig. 1 The overall network of BDMFuse: (a) overall structure of the training phase; (b) overall structure of the testing phase
图 1 BDMFuse 的整体网络架构: (a) 训练阶段的整体架构; (b) 测试阶段的整体架构

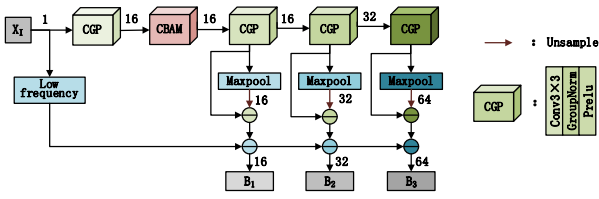

Fig. 2 Base encoder schematic
图2 基础编码器架构

hensive information, we introduce multi-scale feature extraction. Maximum pooling and up-sampling operations are applied to features of different scales to extract high-frequency information, thereby removing high-frequency components from the features. The pooling operation reduces the feature size by half, and to maintain the image size, bilinear interpolation-based up-sampling is adopted.

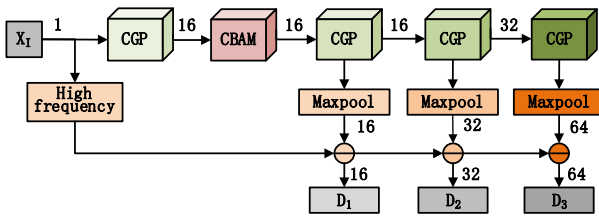

Fig. 3 Detail encoder schematic
图3 细节编码器架构

The detail encoder network is illustrated in Fig. 3, and its architecture bears resemblance to the base encoder. However, the detail encoder employs two methods to obtain the high-frequency information of the image. One approach is to utilize a high-pass filter, while the other involves convolutional operations. Maximum pooling operation is taken directly on image features of different scales in convolution operation to obtain the high frequency information of the image. In this process, the CGP convolution blocks in the network all employ 3x3 convolution kernels with a stride of 1. Transitioning through the CGP convolution block alters only the number of channels and does not affect the image size.

The compensation encoder is shown in Fig. 4. This encoder is constructed to complement the image feature

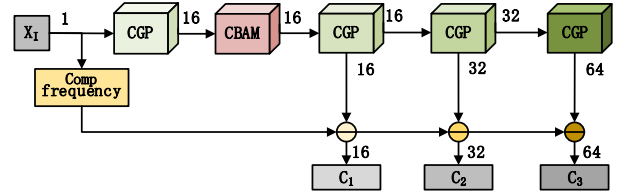

Fig. 4 Compensation encoder schematic
图4 补偿编码器架构

information, so only the basic convolutional processing of the rest of the encoder is retained without any other additional operations.

2.3 Decoder

2.3.1 Decoder network

Initially, the corresponding low-frequency information and high-frequency information of different scales are fused. As shown in Fig. 5(a), $F_b^n (n \in \{1, 2, 3\})$ refers to the multi-scale low-frequency features, $F_d^n (n \in \{1, 2, 3\})$ denotes the multi-scale high-frequency features, and $F_c^n (n \in \{1, 2, 3\})$ represents the multi-scale compensation features. Since the compensation features may increase image artifacts, we add hyperparameter β to modulate the multi-scale compensation features. The size of F_d^n differs from the rest of the image sizes, so up-sampling is achieved through an inverse convolution operation for F_d^n . Finally, F_b^n , F_d^n , and F_c^n are summed to obtain the multi-scale feature $F_n (n \in \{1, 2, 3\})$.

In order to be able to make the image learn more multi-scale information, we obtain the attention map of the corresponding scale from F_n and multiply it with the fused image. Then multi-scale fusion is performed, as shown in Fig. 5(b). F_3 is spliced with F_2 after the CGS module is aligned with the number of F_2 channels, and then sent to Fusion to achieve fusion. After F_3 and F_2 are fused, they are passed through CGS to maintain the same number of channels as F_1 . Then, they are concatenated with F_1 and sent into the Fusion module. The Fusion module^[29] is shown in Fig. 6. We introduce hyperparameter to the Fusion module to enhance its applicability to our proposed network. Finally, image reconstruction is achieved by two CGS modules. The CGS convolutional blocks in the network adopt 3x3 convolutional kernels with a step size of 1. The CGS convolutional blocks only change the number of channels and do not change the im-

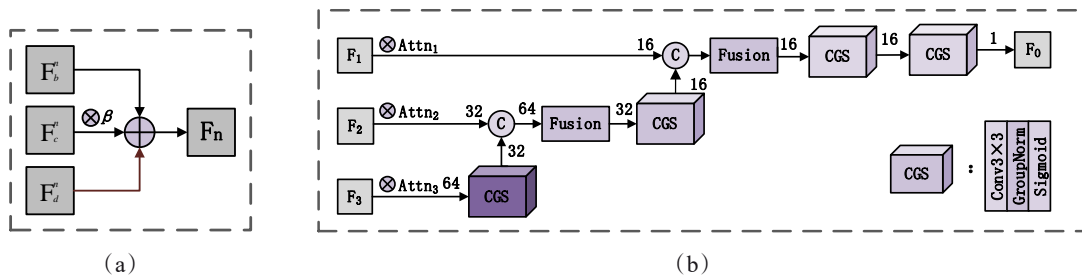

Fig. 5 Decoder schematic: (a) BDC-fusion; (b) multi-fusion
图5 解码器架构: (a) BDC-融合; (b) 多尺度融合

age size.

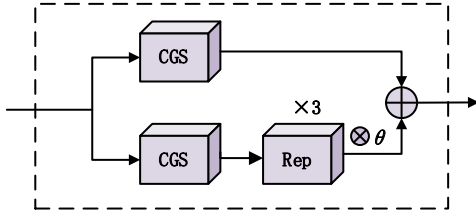

Fig. 6 Fusion module
图 6 融合模块

2.3.2 Attention strategy

Our computation of F_n weights draws inspiration from ASFF (adaptively spatial feature fusion) [30]. F_n has the same size but different numbers of channels. We adjust different number of channels for F_n to obtain three attention maps to extract the weight values of the corresponding scales. The formula is shown below:

$$\omega_1^n, \omega_2^n, \omega_3^n = \text{softmax}(F_{1 \rightarrow n}, F_{2 \rightarrow n}, F_{3 \rightarrow n}), (n, i \in \{1, 2, 3\}), (5)$$

where, $\omega_1^n, \omega_2^n, \omega_3^n$ denote the individual weights of F_n from the n th layer, and $F_{1 \rightarrow n}, F_{2 \rightarrow n}, F_{3 \rightarrow n}$ denote the number of channels of all the layers adjusted to the number of channels of the n th layer by the CGP convolution block. The softmax function is shown below:

$$\text{softmax}(F_{1 \rightarrow n}, F_{2 \rightarrow n}, F_{3 \rightarrow n}) = \frac{e^{F_{i \rightarrow n}}}{e^{F_{1 \rightarrow n}} + e^{F_{2 \rightarrow n}} + e^{F_{3 \rightarrow n}}}, (n, i \in \{1, 2, 3\}) \quad (6)$$

The weights corresponding to F_n are multiplied by F_n to optimise the F_n features as follows:

$$F_n = F_n \times \omega_n^n \quad (7)$$

where ω_n^n is the corresponding weight of F_n in the n th layer of the attention graph.

Taking Attention-3 as an example, Fig. 7 illustrates how to obtain the weights of F_3 . We input F_n into the CGP convolution block, adjust the number of channels of F_1 and F_2 to match that of F_3 , and obtain the feature maps. Subsequently, the three feature maps are concatenated, and the weight value of each feature map is calculated using softmax. Finally, the corresponding weight of F_3 is extracted and multiplied by F_3 to optimize its features. In this process, the CGP convolution blocks all employ 1×1 convolution kernels with a stride of 1.

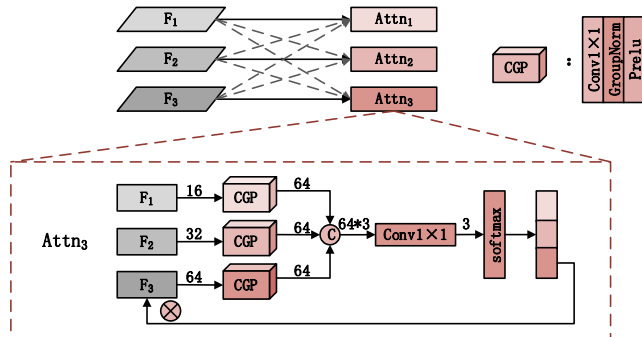

Fig. 7 Attention strategy
图 7 注意力策略

2.4 Training strategy

Our training strategy is similar to DenseFuse. In the training phase, the fusion network is discarded. Through training, we expect the encoder to extract multi-scale depth features and the decoder to reconstruct the image based on these features. This training strategy can leave more choice space for the fusion layer.

In the training phase, the loss function L_{total} is defined as follows:

$$L_{\text{total}} = L_p + \lambda L_s + \lambda/2(L_{s2} + L_{s1}) \quad (8)$$

where L_p and L_s denote the pixel loss and structural similarity loss between the input image and the output image respectively. λ is a measure between L_p, L_s, L_{s1} and L_{s2} .

L_p is calculated by Eq. (9):

$$L_p = \|O - I\|^2 \quad (9)$$

where O and I denote the output and input images, respectively. L_p calculates the square of the difference between the output image and the input image, aiming to ensure that the reconstructed image is similar to the source image at the pixel level.

L_s is obtained from Eq. (10):

$$L_s = 1 - \text{SSIM}(O, I) \quad (10)$$

where $\text{SSIM}(-)$ represents the structural similarity measure. When the value of $\text{SSIM}(-)$ is larger, it indicates a higher structural similarity between the output image O and the input image I .

The Fusion module is introduced in the decoder network to retain more feature information. However, it tends to ignore the structural information of the image to some extent. To address this, L_{s2} and L_{s1} losses are introduced.

L_{s2} is obtained from Eq. (11):

$$L_{s2} = 1 - \text{SSIM}(f_{3+2}, F(f_3, f_2)) \quad (11)$$

where f_{3+2} is the result of summing the multi-scale features F_2 and F_3 , while $F(f_3, f_2)$ is the fusion result obtained after the Fusion module.

L_{s1} is obtained from Eq. (12):

$$L_{s1} = 1 - \text{SSIM}(f_{2+1}, F(f_2, f_1)) \quad (12)$$

where f_{2+1} is the result of fusion of multi-scale features F_2 and F_3 and then summed with F_1 , and $F(f_2, f_1)$ is the fusion result obtained after the Fusion module.

The goal of the training phase is to train an autoencoder network capable of effectively extracting image features and reconstructing images. We employ 1 600 images from FLIR as input images for network training. The training samples are randomly cropped to 224×224 . We set the parameter λ to 10 to train the network.

3 Experimental results and analysis

In this section, we will validate our proposed fusion method through a series of experiments. The network is executed on an NVIDIA GeForce RTX 2080Ti and implemented using the PyTorch framework.

3.1 Experimental setting

In this experiment, images are selected from the TNO, RoadScene [31], and LLVIP [32] datasets, and our proposed fusion network is compared with nine typical fusion networks (DenseFuse, RFN-Nest, FusionGAN [33],

Table 1 Average quality evaluation metrics for ablation experiments**表1 消融实验的平均质量评估指标**

	EN	MI	SD	AG	VIF	SCD	MS_SSIM
SE-Attention	6.8501	13.7001	34.7315	3.7415	0.9612	1.8192	0.9416
ECA-Attention	6.9504	13.9008	40.6716	3.5503	0.9548	1.6514	0.9148
No-Attention	7.1774	14.3547	40.2576	4.2096	1.3605	1.8801	0.9306
No-Comp Encoder	6.8728	13.7456	38.0053	2.9682	0.9219	1.8060	0.9403
No-Fusion Module	7.2129	14.4259	40.8263	3.7076	1.2727	1.8870	0.9277
No-Strategy	7.0291	14.0581	37.9805	3.3666	1.0851	1.8935	0.9511
No-Strategy& No-Multi-scale	6.5910	13.1819	35.0411	3.2785	0.8063	1.6111	0.9216
Proposed	7.2525	14.5050	43.6183	4.1627	1.4128	1.8715	0.9207

U2Fusion^[34], CSF^[35], SEDR, SwinFusion^[36], SeAFusion, CDDFuse) to evaluate its performance. We select seven commonly used image quality evaluation metrics for objective quality evaluation of fused images, which are entropy (EN)^[37], mutual information (MI)^[38], standard deviation (SD)^[39], average gradient (AG)^[40], visual information fidelity (VIF)^[41], the sum of the correlations of differences (SCD)^[42], multi-scale structural similarity measure (MS_SSIM)^[43]. Among them, EN is an objective evaluation metric that measures how much information the image contains. MI is used to measure the amount of information transferred from the source image

to the fused image. SD reflects the distribution and contrast of the fused image. AG is a metric used to evaluate the sharpness and detail of an image. VIF measures the information fidelity of the fused image. SCD is a measure of the differences between the fused image and the original image. MS_SSIM is a similarity-based evaluation metric.

3.2 Ablation experiment

The proposed network incorporates compensated encoders into the encoder network and introduces an attention strategy along with a Fusion module for multi-scale fusion in the decoder network. To validate the efficacy of

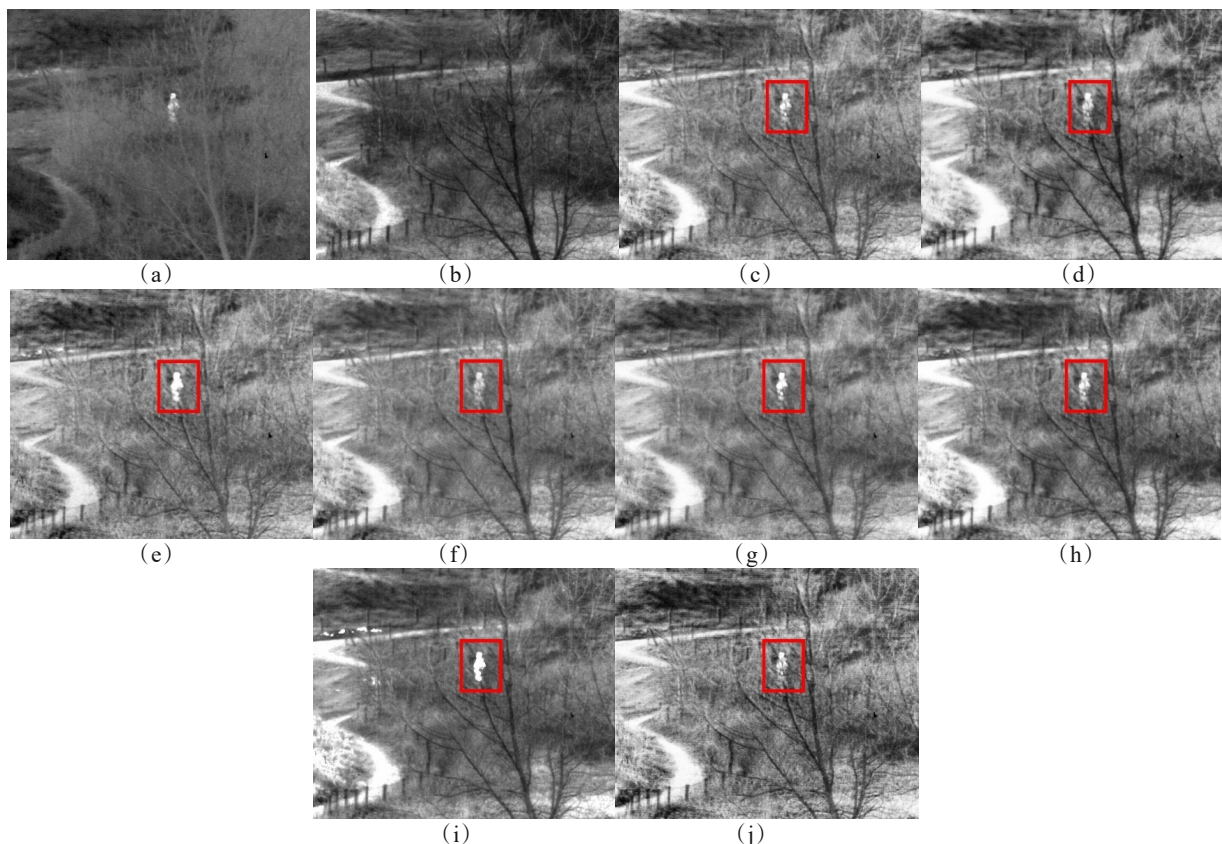

Fig. 8 Fusion image of ablation experiments: (a) IR; (b) VIS; (c) SE-Attention; (d) ECA-Attention; (e) No-Attention; (f) No-Comp Encoder; (g) No-Fusion Module; (h) No-Strategy; (i) No-Strategy & No-Multi-scale; (j) proposed

图8 消融实验的融合结果:(a) 红外图像;(b) 可见光图像;(c) SE-注意力;(d) ECA-注意力;(e) 无注意力;(f) 无补偿编码器;(g) 无Fusion模块;(h) 无策略;(i) 无策略&无多尺度;(j) 本文所提方法

these strategies, the article includes ablation experiments. Additionally, to further assess the benefits of the attention strategies, the article compares two attention mechanisms SE and ECA with the strategies we have adopted. As illustrated in Fig. 8, our proposed network demonstrates superior visual fusion effects in the fused image. Specifically, it effectively highlights the presence of the villain in the infrared image while preserving the dendritic texture features in the visible image. Specifically, it effectively highlights the presence of a person in infrared images while preserving the textural features of tree branches in visible image.

To further demonstrate the superiority of our method, we conducted a quantitative analysis using test results from 40 pairs of infrared and visible images selected from the TNO dataset. The optimal values are highlighted in bold black. As shown in Table 1, our proposed network achieves optimal values for the EN, MI, SD, and VIF metrics. These results provide additional evidence of the effectiveness of our adopted approach.

3.3 Analysis of experimental results

3.3.1 Subjective analysis

Subjective qualitative comparisons of the nine existing fusion methods with our fusion method are presented in Figs. 9-11. As depicted in the figures, all fusion methods effectively fuse infrared and visible images, but notable differences in visual quality are observed. FusionGAN retains more information from the infrared im-

age during fusion, which can result in blurred image details. The remaining fusion methods retain more detailed information from the visible image, especially SwinFusion, SeAFusion and CDDFuse. For example, in Fig. 9, the cloud information present in the infrared image is missing. Our proposed network retains more light and shadow information, as illustrated in Fig. 10, indicating its enhanced ability to perceive light. To further validate this, we conducted experiments on the LLVIP dataset. LLVIP is a dataset for low-light vision paired with visible and infrared images. As demonstrated in Fig. 11, our fused images reveal the basic outline of the manhole cover even under low-light conditions.

3.3.2 Quantitative analysis

In addition to subjective qualitative analysis, we employ objective quantitative analysis to measure the performance of the proposed method. The quantitative evaluation results for the test sets of 40 pairs from TNO, 100 pairs from RoadScene, and 100 pairs from LLVIP are shown in Tables 2-4. The best value is indicated in bold black text, and the second-best value is underlined. Using the experimental results of the LLVIP dataset as an example, we achieve the highest values on five indicators: EN, MI, SD, VIF and SCD. This demonstrates our network's capability to effectively extract image details. The results from the other two datasets show that while our proposed fusion method may fall slightly short of the optimal values in some evaluation metrics, the outcomes are relatively balanced across all metrics

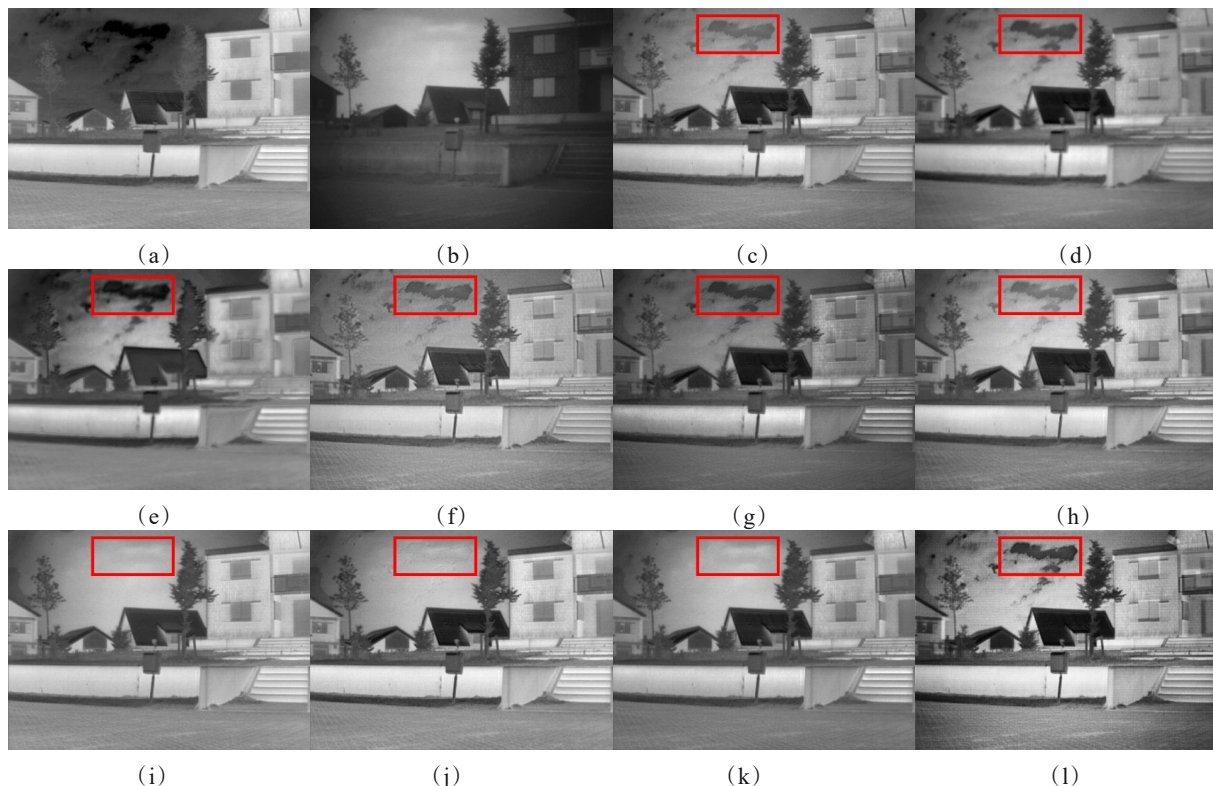

Fig. 9 Fusion image of TNO: (a) IR; (b) VIS; (c) DenseFuse; (d) RFN-Nest; (e) FusionGAN; (f) U2Fusion; (g) CSF; (h) SEDR; (i) SwinFusion; (j) SeAFusion; (k) CDDFuse; (l) proposed

图9 TNO图像的融合结果: (a) 红外图像; (b) 可见光图像; (c) DenseFuse; (d) RFN-Nest; (e) FusionGAN; (f) U2Fusion; (g) CSF; (h) SEDR; (i) SwinFusion; (j) SeAFusion; (k) CDDFuse; (l) 本文所提方法

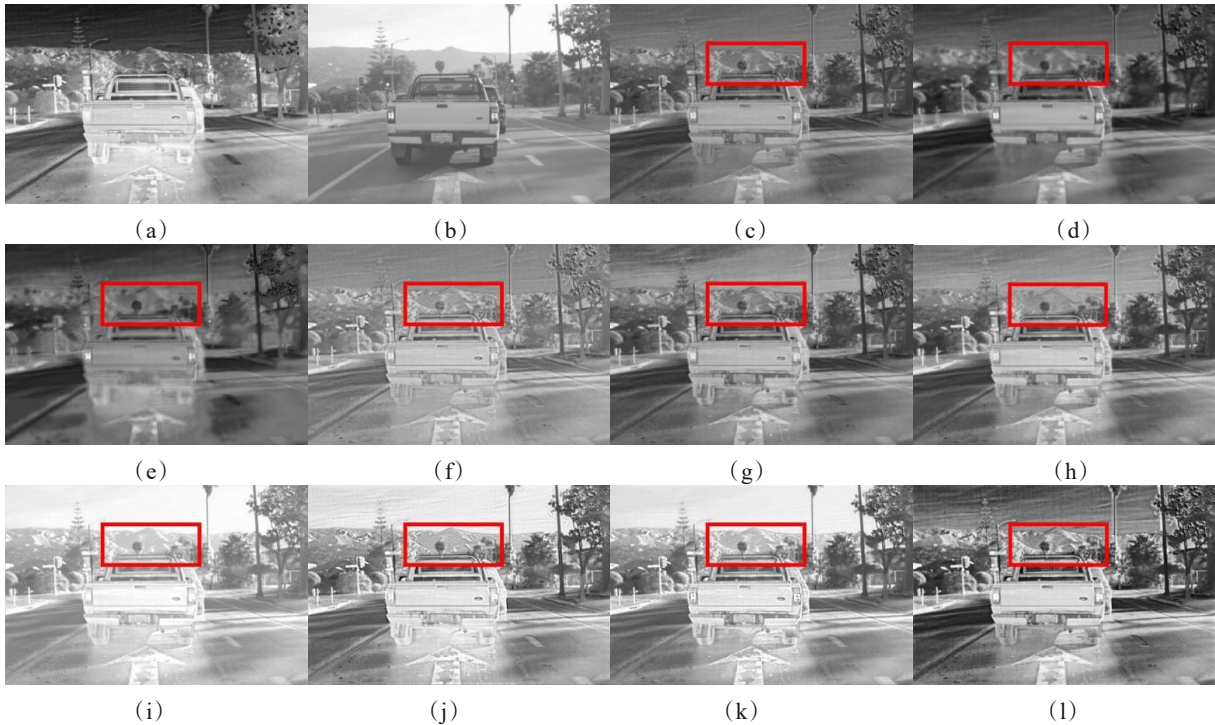

Fig. 10 Fusion image of RoadScene: (a) IR; (b) VIS; (c) DenseFuse; (d) RFN-Nest; (e) FusionGAN; (f) U2Fusion; (g) CSF; (h) SEDR; (i) SwinFusion; (j) SeAFusion; (k) CDDFuse; (l) proposed

图 10 RoadScene 图像的融合结果: (a) 红外图像; (b) 可见光图像; (c) DenseFuse; (d) RFN-Nest; (e) FusionGAN; (f) U2Fusion; (g) CSF; (h) SEDR; (i) SwinFusion; (j) SeAFusion; (k) CDDFuse; (l) 本文所提方法

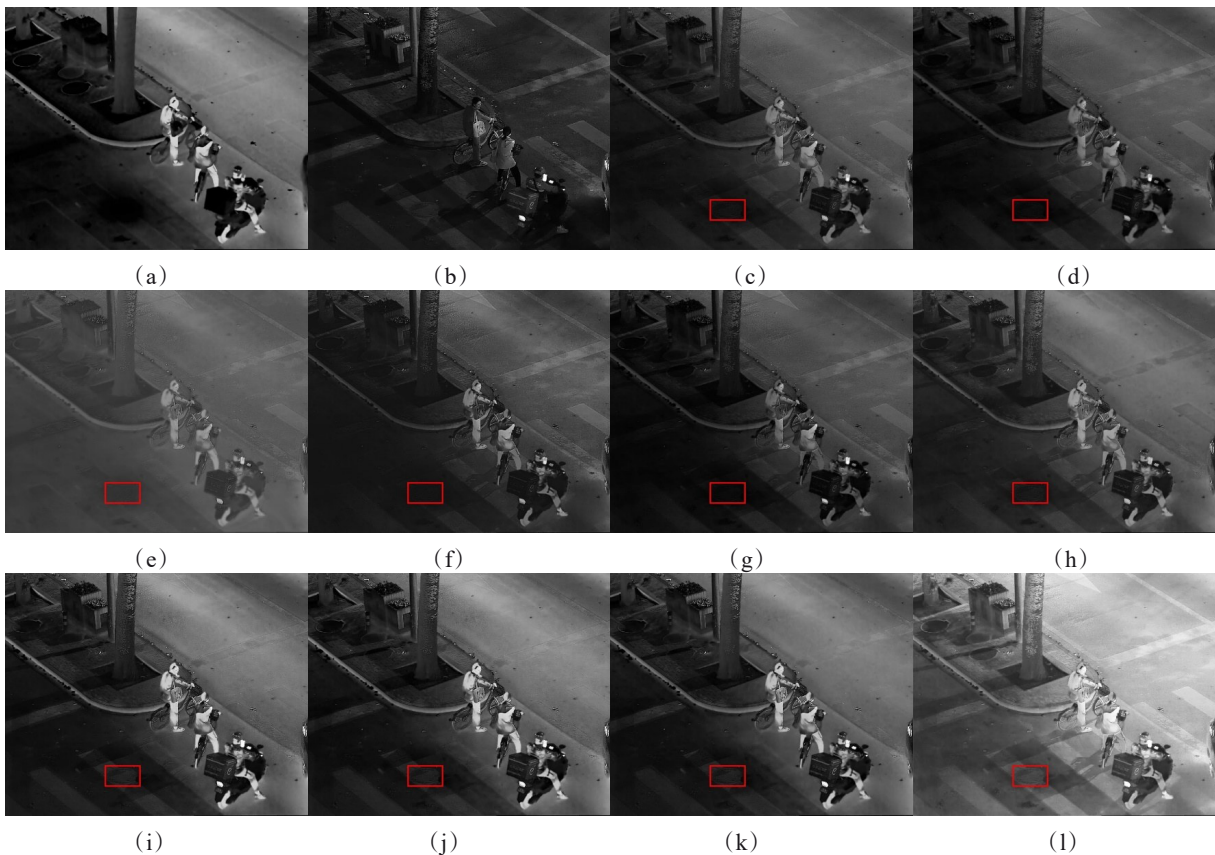

Fig. 11 Fusion image of LLVIP: (a) IR; (b) VIS; (c) DenseFuse; (d) RFN-Nest; (e) FusionGAN; (f) U2Fusion; (g) CSF; (h) SEDR; (i) SwinFusion; (j) SeAFusion; (k) CDDFuse; (l) our proposed

图 11 LLVIP 图像的融合结果: (a) 红外图像; (b) 可见光图像; (c) DenseFuse; (d) RFN-Nest; (e) FusionGAN; (f) U2Fusion; (g) CSF; (h) SEDR; (i) SwinFusion; (j) SeAFusion; (k) CDDFuse; (l) 本文所提方法

and generally superior to other fusion methods. Additionally, the experimental results from all three datasets indicate that our method has good feasibility and generalizability.

Table 2 Average quality evaluation metrics for 40 pairs of TNO fused images
表2 40对TNO融合图像的平均质量评估指标

	EN	MI	SD	AG	VIF	SCD	MS_SSI M
DenseFuse	6.7933	13.5867	33.0055	3.8958	1.1141	1.8951	0.9379
RFN-Nest	6.9889	13.9777	35.2026	2.8619	1.1218	1.8710	0.9138
FusionGAN	6.5073	13.0147	26.4478	2.4276	0.7408	1.1339	0.7511
U2Fusion	6.4745	12.9489	24.9858	3.8414	0.7371	1.6542	0.9433
CSF	6.9295	13.8591	34.2342	3.8565	1.2221	1.8503	0.9190
SEDR	6.8795	13.7590	39.0527	4.1491	1.5546	1.8554	0.8946
SwinFusion	6.6156	13.2311	31.0339	3.4971	0.7228	1.7147	0.8992
SeAFusion	7.1474	14.2949	39.9100	5.6162	1.7369	1.7323	0.8553
CDDFuse	7.0582	14.1164	39.1751	5.2135	1.3976	1.7966	0.8795
Proposed	7.3544	14.7088	44.5808	5.9907	1.8274	1.8784	0.8935

Table 3 Average quality evaluation metrics for 100 pairs of RoadScene fused images
表3 100对RoadScene融合图像的平均质量评估指标

	EN	MI	SD	AG	VIF	SCD	MS_SSI M
DenseFuse	7.2684	14.5368	43.1679	4.5979	0.6504	1.6552	0.9220
RFN-Nest	7.3492	14.6984	46.1085	3.1668	0.6091	1.6837	0.8671
FusionGAN	7.0540	14.1079	39.0645	3.2246	0.4805	1.0496	0.7547
U2Fusion	7.0815	14.1629	37.8472	5.2514	0.6338	1.3866	0.9148
CSF	7.4257	14.8514	47.9828	5.0241	0.7952	1.7282	0.9261
SEDR	7.4499	14.8999	49.3581	4.9322	0.8286	1.6978	0.9005
SwinFusion	6.9712	13.9424	45.1634	4.3312	0.7275	1.5772	0.8470
SeAFusion	7.5117	15.0234	56.1119	6.8737	1.0949	1.6732	0.8786
CDDFuse	7.5003	15.0007	56.4331	6.5083	1.1120	1.7105	0.8740
Proposed	7.5623	15.1246	53.1000	6.5506	1.0359	1.7766	0.9353

Table 4 Average quality evaluation metrics for 100 pairs of LLVIP fused images
表4 100对LLVIP融合图像的平均质量评估指标

	EN	MI	SD	AG	VIF	SCD	MS_SSI M
DenseFuse	6.9740	13.9480	36.7708	2.8641	0.4617	1.3835	0.9224
RFN-Nest	7.0028	14.0055	37.8919	2.2445	0.4216	1.4154	0.8981
FusionGAN	6.4153	12.8306	26.1540	2.0102	0.2746	0.7521	0.7865
U2Fusion	6.6531	13.3062	34.9659	3.3391	0.5283	1.2755	0.9098
CSF	6.8283	13.6566	35.3773	2.7960	0.4564	1.3621	0.9109
SEDR	6.8877	13.7795	36.5430	2.6319	0.4495	1.2546	0.8834
SwinFusion	7.3844	14.7688	50.8104	4.2064	0.9087	1.5887	0.9451
SeAFusion	7.4193	14.8386	50.4468	4.1898	0.9062	1.6259	0.9435
CDDFuse	7.3134	14.6267	48.3450	3.8052	0.8171	1.5889	0.9337
Proposed	7.5398	15.0795	52.9415	3.8464	0.9889	1.7071	0.9250

4 Conclusions

The article constructs a base encoder and a detail encoder based on the optimization problem to extract low-frequency and high-frequency information from the image. Additionally, a compensation encoder is proposed to supplement the missing information. To capture more feature information, a multi-scale approach is introduced for extracting image features. The decoder combines low-frequency, high-frequency, and compensation information to generate the fused image at different scales. Attention maps are then derived from these fused images, and the corresponding weights are multiplied with the fused images at different scales. Finally, the Fusion module is introduced for multi-scale fusion to achieve image reconstruction. During the training phase, the three encoders and one decoder are trained according to the loss function to ensure the image reconstruction capability. In the testing phase, the low-frequency, high-frequency, and compensatory information at different scales, decomposed by the encoder, are fed into the fusion layer to integrate the corresponding infrared and visible images. These are then sent into the decoder for image reconstruction, resulting in the final fused image.

The network undergoes comparative experiments on the TNO, RoadScene, and LLVIP datasets. The results demonstrate that both the subjective fusion effect and the overall objective evaluations of the proposed network outperform those of the comparison methods, showing good generalization across datasets.

References

- [1] Zhang H, Xu H, Tian X, et al. Image fusion meets deep learning: A survey and perspective [J]. *Information Fusion*, 2021, 76 (11): 323–336.
- [2] Li J, Liu J, Zhou S, et al. Infrared and visible image fusion based on residual dense network and gradient loss [J]. *Infrared Physics & Technology*, 2023, 128: 104486.
- [3] Meher B, Agrawal S, Panda R, et al. A survey on region based image fusion methods [J]. *Information Fusion*, 2019, 48: 119–132.
- [4] Li S, Kang X, Fang L, et al. Pixel-level image fusion: A survey of the state of the art [J]. *Information Fusion*, 2017, 33: 100–112.
- [5] Ma J, Chen C, Li C, et al. Infrared and visible image fusion via gradient transfer and total variation minimization [J]. *Information Fusion*, 2016, 31: 100–109.
- [6] Chen J, Li X, Luo L, et al. Infrared and visible image fusion based on target-enhanced multiscale transform decomposition [J]. *Information Sciences*, 2020, 508: 64–78.
- [7] Li J, Liu J, Zhou S, et al. Learning a coordinated network for detail-refinement multiexposure image fusion [J]. *IEEE Transactions on Circuits and Systems for Video Technology*, 2022, 33(2): 713–727.
- [8] Li H, Wu X J, Kittler J. RFN-Nest: An end-to-end residual fusion network for infrared and visible images [J]. *Information Fusion*, 2021, 73: 72–86.
- [9] Long Y, Jia H, Zhong Y, et al. RXDNFuse: A aggregated residual dense network for infrared and visible image fusion [J]. *Information Fusion*, 2021, 69: 128–141.
- [10] Xu H, Liang P, Yu W, et al. Learning a generative model for fusing infrared and visible images via conditional generative adversarial network with dual discriminators [C]. *IJCAI*, 2019: 3954–3960.
- [11] Lin Z P, Luo Y H, Li B Y, et al. Gradient-aware channel attention network for infrared small target image denoising before detection [J]. *Journal of Infrared and Millimeter Waves*, 2024, 43 (2): 254–260.

林再平, 罗伊杭, 李博扬, 等. 基于梯度可感知通道注意力模块的红外小目标检测前去噪网络[J]. *红外与毫米波学报*, 2024, 43 (2): 254–260.

- [12] Li B, Wang Y, Wang L, et al. Monte Carlo linear clustering with single-point supervision is enough for infrared small target detection [C]. Proceedings of the IEEE/CVF International Conference on Computer Vision, 2023: 1009–1019.
- [13] Li B, Wang L, Wang Y, et al. Mixed-precision network quantization for infrared small target segmentation [J]. IEEE Transactions on Geoscience and Remote Sensing, 2024: 62.
- [14] Liu T, Yang J, Li B, et al. Infrared small target detection via non-convex tensor tucker decomposition with factor prior [J]. IEEE Transactions on Geoscience and Remote Sensing, 2023, 61: 5617317.
- [15] Li H, Wu X J. DenseFuse: A fusion approach to infrared and visible images [J]. IEEE Transactions on Image Processing, 2018, 28(5): 2614–2623.
- [16] Li Q, Han G, Liu P, et al. A multilevel hybrid transmission network for infrared and visible image fusion [J]. IEEE Transactions on Instrumentation and Measurement, 2022, 71: 1–14.
- [17] Zhao Z, Bai H, Zhang J, et al. Cddfuse: Correlation-driven dual-branch feature decomposition for multi-modality image fusion [C]. Proceedings of the IEEE/CVF Conference on Computer Vision and Pattern Recognition, 2023: 5906–5916.
- [18] Tang L, Xiang X, Zhang H, et al. DIVFusion: Darkness-free infrared and visible image fusion [J]. Information Fusion, 2023, 91: 477–493.
- [19] Tang L, Yuan J, Ma J. Image fusion in the loop of high-level vision tasks: A semantic-aware real-time infrared and visible image fusion network [J]. Information Fusion, 2022, 82: 28–42.
- [20] Piella G. A general framework for multiresolution image fusion: from pixels to regions [J]. Information fusion, 2003, 4(4): 259–280.
- [21] Sadjadi F. Comparative image fusion analysis [C]. 2005 IEEE Computer Society Conference on Computer Vision and Pattern Recognition (CVPR'05)–Workshops, 2005: 8–8.
- [22] Pu T, Ni G. Contrast-based image fusion using the discrete wavelet transform [J]. Optical Engineering, 2000, 39(8): 2075–2082.
- [23] Da Cunha A L, Zhou J, Do M N. The nonsubsampling contourlet transform: theory, design, and applications [J]. IEEE Transactions on Image Processing, 2006, 15(10): 3089–3101.
- [24] Lin Z P, Li B Y, Li M, et al. Light-weight infrared small target detection combining cross-scale feature fusion with bottleneck attention module [J]. Journal of Infrared and Millimeter Wave, 2022, 41(06): 1102–1112.
林再平, 李博扬, 李森, 等. 结合跨尺度特征融合与瓶颈注意力模块的轻量型红外小目标检测网络[J]. 红外与毫米波学报, 2022, 41(06): 1102–1112.
- [25] Jian L, Yang X, Liu Z, et al. SEDRFuse: A symmetric encoder-decoder with residual block network for infrared and visible image fusion [J]. IEEE Transactions on Instrumentation and Measurement, 2020, 70: 1–15.
- [26] Wang Z, Wu Y, Wang J, et al. Res2Fusion: Infrared and visible image fusion based on dense Res2net and double nonlocal attention models [J]. IEEE Transactions on Instrumentation and Measurement, 2022, 71: 1–12.
- [27] Zhao Z, Xu S, Zhang J, et al. Efficient and model-based infrared and visible image fusion via algorithm unrolling [J]. IEEE Transactions on Circuits and Systems for Video Technology, 2021, 32(3): 1186–1196.
- [28] Woo S, Park J, Lee J Y, et al. Cbam: Convolutional block attention module [C]. Proceedings of the European Conference on Computer Vision (ECCV). 2018: 3–19.
- [29] Zhao Y, Lv W, Xu S, et al. Detrs beat yolos on real-time object detection [C]. Proceedings of the IEEE/CVF Conference on Computer Vision and Pattern Recognition. 2024: 16965–16974.
- [30] Liu S, Huang D, Wang Y. Learning spatial fusion for single-shot object detection [J]. arXiv preprint arXiv:1911.09516, 2019.
- [31] Xu H, Ma J, Le Z, et al. FusionDn: A unified densely connected network for image fusion [C]. Proceedings of the AAAI Conference on Artificial Intelligence, 2020, 34(07): 12484–12491.
- [32] Jia X, Zhu C, Li M, et al. LLVIP: A visible-infrared paired dataset for low-light vision [C]. Proceedings of the IEEE/CVF International Conference on Computer Vision, 2021: 3496–3504.
- [33] Ma J, Yu W, Liang P, et al. FusionGAN: A generative adversarial network for infrared and visible image fusion [J]. Information Fusion, 2019, 48: 11–26.
- [34] Xu H, Ma J, Jiang J, et al. U2Fusion: A unified unsupervised image fusion network [J]. IEEE Transactions on Pattern Analysis and Machine Intelligence, 2020, 44(1): 502–518.
- [35] Xu H, Zhang H, Ma J. Classification saliency-based rule for visible and infrared image fusion [J]. IEEE Transactions on Computational Imaging, 2021, 7: 824–836.
- [36] Ma J, Tang L, Fan F, et al. SwinFusion: Cross-domain long-range learning for general image fusion via swin transformer [J]. IEEE/CAA Journal of Automatica Sinica, 2022, 9(7): 1200–1217.
- [37] Roberts J W, Van Aardt J A, Ahmed F B. Assessment of image fusion procedures using entropy, image quality, and multispectral classification [J]. Journal of Applied Remote Sensing, 2008, 2(1): 023522.
- [38] Qu G, Zhang D, Yan P. Information measure for performance of image fusion [J]. Electronics Letters, 2002, 38(7): 1.
- [39] Rao Y J. In-fibre Bragg grating sensors [J]. Measurement Science and Technology, 1997, 8(4): 355.
- [40] Cui G, Feng H, Xu Z, et al. Detail preserved fusion of visible and infrared images using regional saliency extraction and multi-scale image decomposition [J]. Optics Communications, 2015, 341: 199–209.
- [41] Han Y, Cai Y, Cao Y, et al. A new image fusion performance metric based on visual information fidelity [J]. Information Fusion, 2013, 14(2): 127–135.
- [42] Aslantas V, Bendes E. A new image quality metric for image fusion: The sum of the correlations of differences [J]. Aeu-International Journal of Electronics and Communications, 2015, 69(12): 1890–1896.
- [43] Ma K, Zeng K, Wang Z. Perceptual quality assessment for multi-exposure image fusion [J]. IEEE Transactions on Image Processing, 2015, 24(11): 3345–3356.